

Simple Concepts for a Simple Life.



Sliding Doors

ALUFLAM sliding doors are suitable for large openings where maximum vision is required. Our range of designed solutions can accommodate all configurations to suit the aesthetics of the room.

The robust Aluminium profiles have been designed for contemporary styling, featuring square edges with polyamide thermal break insulation to achieve superior thermal performance.

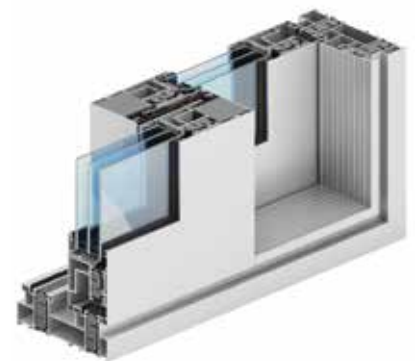

Sliding Doors

- The system design allows for large and stable sliding structures.
- Available in 2,3,& 4 panel configurations based on a double rail system
- Available in double and triple glazed insulated units
- Optional flyscreen system can be incorporated
- The system design offers RC2 level protection (NEN 5096 & ENV 1627)
- Burglar Resistance meets requirements of PAS-24 & SBD

2-rails system, DGU

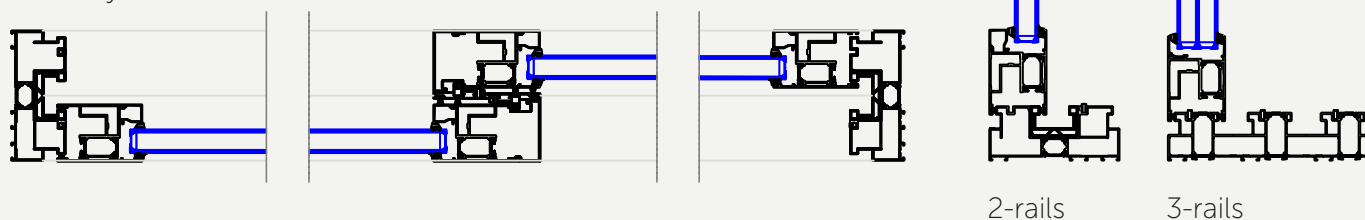

3-rails system, TGU

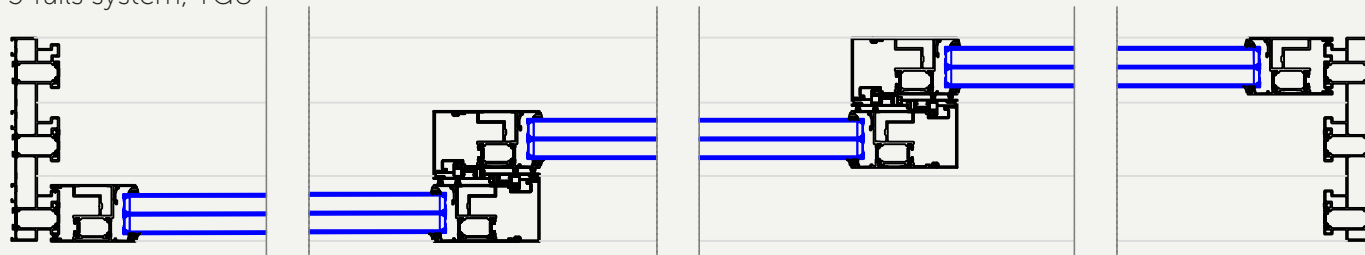

Frame depth / Leaf depth	153 - 239 mm / 67 mm
Glazing range	14 - 52 mm
Maximal size of the structure	3850 x 2550 mm
Thermal insulation	Uf from 1,45 W/m ² K
Air tightness (EN 12207)	Class 4
Water tightness (EN 12208)	Class 9A (600 Pa)
Wind load resistance (EN 12210)	Class C4 (1600Pa)

ALUFLAM A/S
Langebjergvænget 13
4000 Roskilde
DENMARK

Tel. +45 46 75 06 11
Fax +45 46 75 08 11
E-mail: info@aluflam.dk
VAT Reg No 20675136

ALUFLAM[®]
GROUP